

An integrated technology package to transform sugars to polylactic acid



Photo copyright: Sulzer Ltd

Our market offering

Futero, Sulzer and Technip Energies have joined forces to form PLAnet™ Alliance to promote and license a unique, fully integrated technology package that transforms sugars to polylactic acid (PLA). PLAnet offers the possibility of a “one-stop shop” for customers who want to produce PLA.

- PLAnet technology enables the construction of plants of any size up to 100,000 tons PLA production per year.
- The integrated and optimized design provides our clients with both capital (CAPEX) and operating expenditures (OPEX) savings.
- The customer will benefit from the continuous improvement and further development of PLAnet technology.

A wide range of applications

PLA is a versatile, bio-based and biodegradable polymer that replaces petroleum-based plastics in a wide range of applications.

PLA's properties allow it to be used in applications such as thermoforming, fibers and non-wovens, film, injection molding, bottles, rotomolding and 3D printing.

PLA provides the plastics industry with new opportunities to meet challenging product specifications and market demands.

PLA is experiencing a high growth rate with substantial market potential

Bio-based and biodegradable, a sustainable way of producing plastics

PLA is produced from sugars through the combination of different process steps which require specific know-how and capabilities. Our PLAnet technology allows these sugars to be produced from a complete range of first generation raw sugars including wheat, sugar cane, beet, corn and tapioca. The main benefits include:

- Feedstock flexibility
- High yield performances for fermentation
- Food grade and non-GMO PLA products
- Variety of PLA grades and applications
- PLA waste recycling back to the virgin lactic acid with LOOPLA technology
- Fast and easy transition between PLA grades

A proven technology

PLAnet integrates proven technology from Futerro and Sulzer with an optimized process integration provided by Technip Energies.

PLAnet industrial plant references:

- Sugar-to-lactic acid (Futerro): 30kta in Belgium (1992), 50 kta in China (2004)
- Lactide-to-PLA plant (Sulzer): 75kta PLA in Thailand (2018)
- An integrated sugars-to-PLA plant is currently under construction in China utilizing our PLAnet Alliance technologies

Our Integrated offering

Our integrated offering includes:

- Consulting and services to support and build your business cases
- Front End Engineering and Design (FEED) for ISBL facilities with corresponding $\pm 10\%$ CAPEX
- Supply of proprietary equipment and biological strains
- Technical assistance during the project execution phase
- Operating manual and personnel training
- Plant optimization services

Worldwide support

Through the Alliance, Technip Energies provides a single point of contact. Technip Energies is a world leader in technologies and engineering. At your request, we can support you worldwide through all the project phases.

“
PLAnet offers the possibility of a “one-stop shop” for customers who want to produce PLA.
”

PLAnet™ Simplified Block Flow Diagram

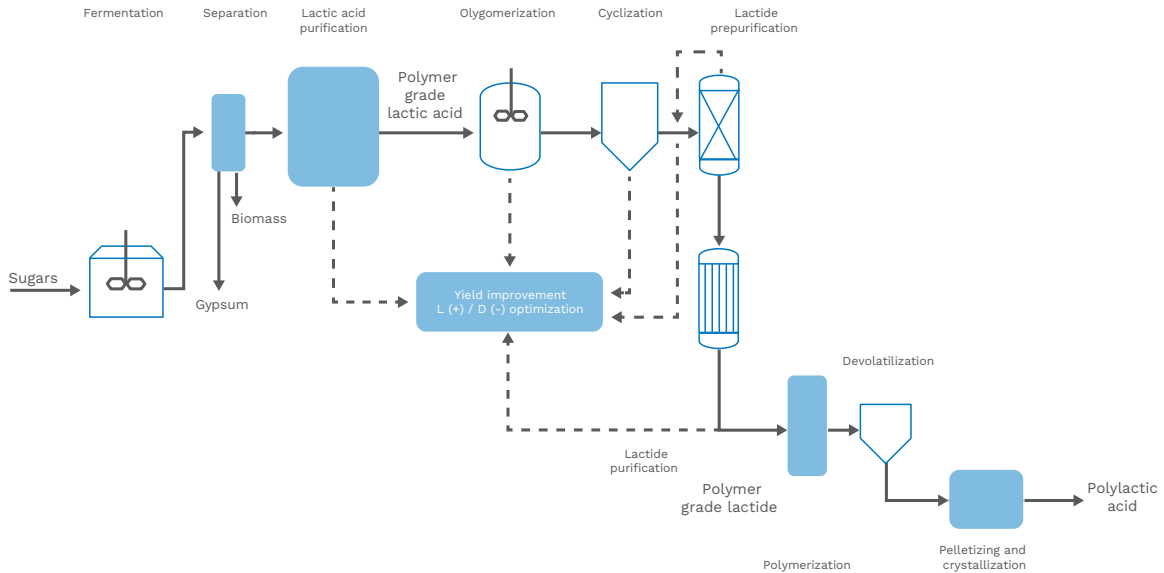

Isabelle Navier
isabelle.navier@technipenergies.com
+33 6 81 26 96 31

Alessandra Adriatico
alessandra.adriatico@technipenergies.com
+39 06 65 98 45 17

www.technipenergies.com