

Where energies make tomorrow ●

Integrated LNG-to-Power

Affordable plug-and-play clean power. Now.

iLNGP™
by T.EN

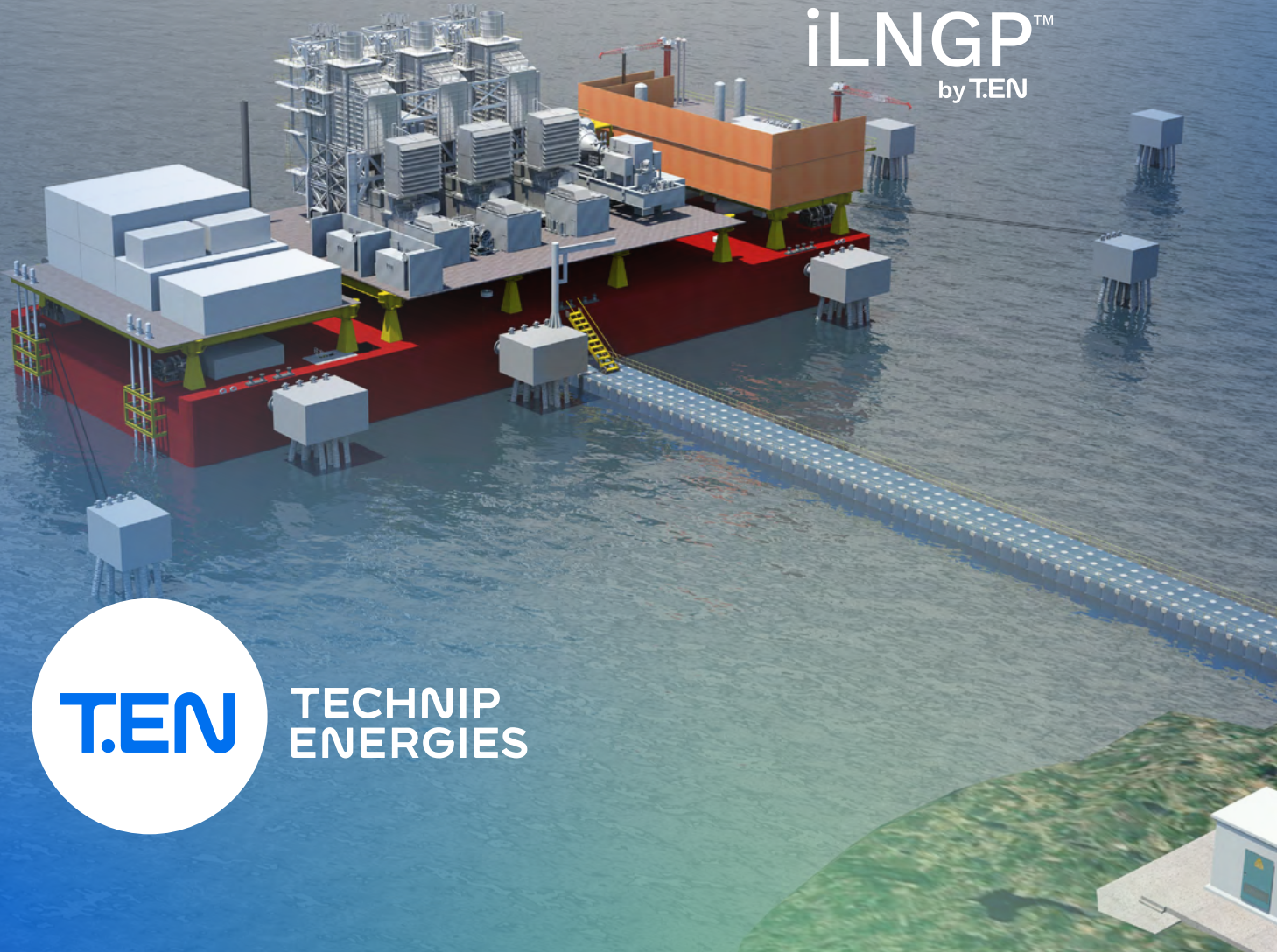

TECHNIP
ENERGIES

iLNGP by T.EN™: Innovative plug-and-play power solution

Enabling cleaner power production in remote or critical locations with plug-and-play floating solutions that simplify the traditional LNG-to-Power value chain.

An integrated LNG receiving terminal and power plant on a single barge:

- LNG receiving marine facilities
- LNG storage

Unlock clean power production for complex projects. Today.

SECURE PROJECT EXECUTION

- In remote, complex environments, islands and archipelagos
- Where gas pipe is not economically viable
- Where gas is unavailable
- Where mining projects need clean power rapidly deployed

ENSURE PROJECT IMPLEMENTATION

- Where local construction conditions are unpredictable
- Where LNG-to-Power unit may need relocation

PROTECT THE ENVIRONMENT

- Up to 20 times less CO₂ emissions than coal power
- No SO_x, no particle, 15 times less NO_x emitted
- No impact on harbor seawater temperature

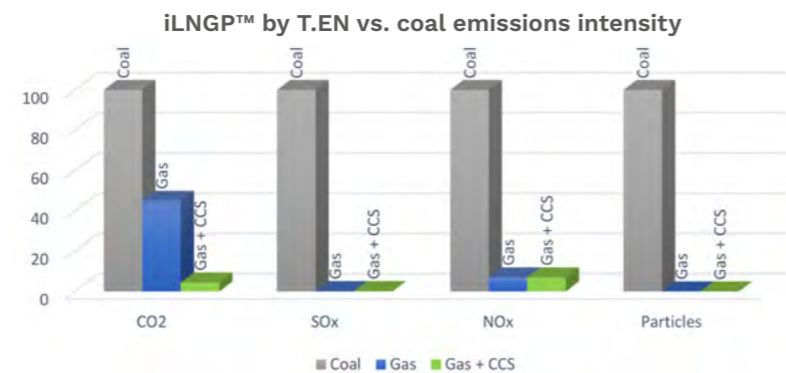

Combined cycle base case 150 MW to 450 MW

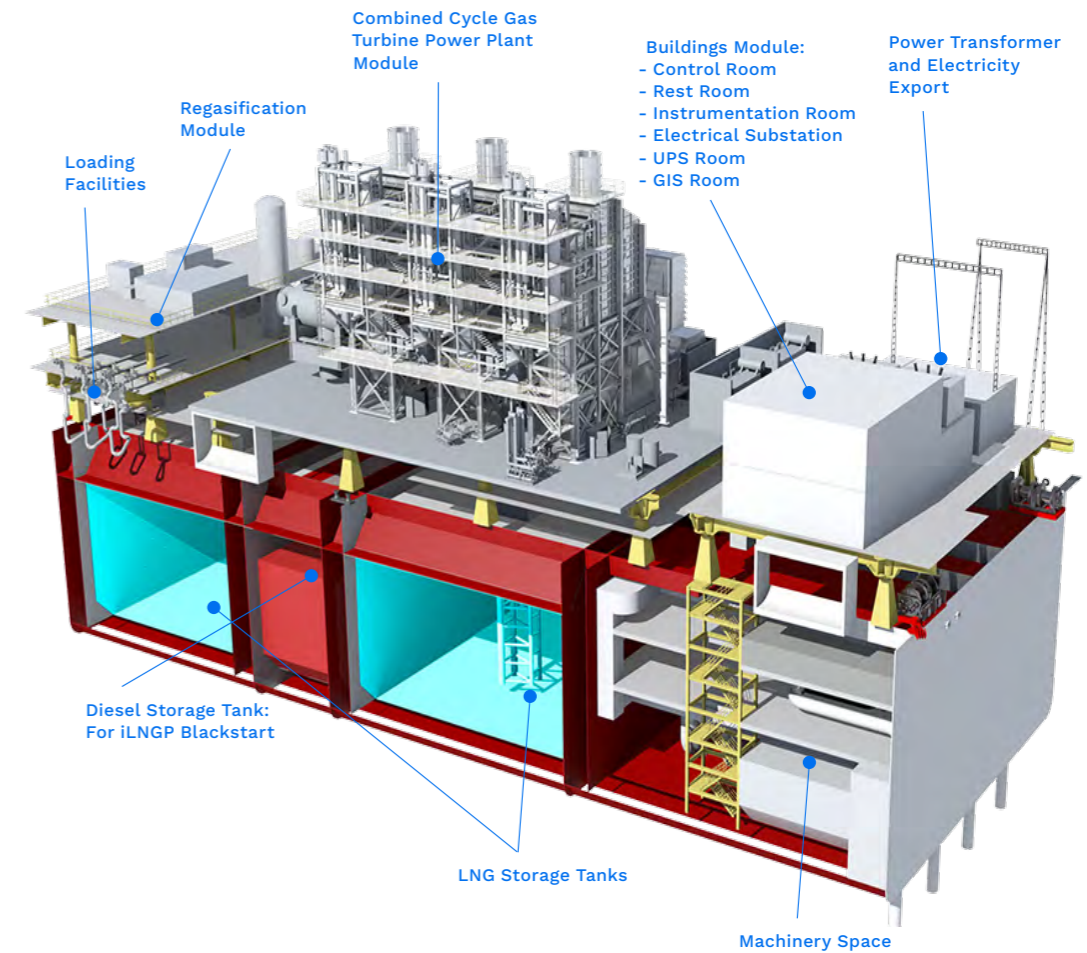

iLNGP by T.EN™ features

- Scalable base case 150 MW to 450 MW CCGT with heat recovery enabling lowest LNG consumption
- Plug-and-play integrated solution, autonomous black start capability
- Extended range 50 MW to 1 300 MW for special applications
- Gas engine alternative
- One month minimum autonomy
- At-quay or nearshore jetty deployment
- Direct ship-to-ship LNG reception from LNG carrier
- Inherent safety, first design to receive Approval in Principle
- No seawater temperature impact with wet cooling tower option

Traditional solution vs. iLNGP by T.EN™

TRADITIONAL DEVELOPMENT SEQUENCE



iLNGP BY T.EN™ DEVELOPMENT SEQUENCE



MAIN BENEFITS

- Reduced risks and uncertainties of local construction
- Secured cost and delivery schedule
- Reduced permitting lead time
- Low CAPEX and OPEX
- Relocatable assets (easy disconnection)
- Reduced time to market
- Reduced carbon footprint
- No SOx and particles
- No impact on harbor seawater temperature
- Optimum efficiency near 60%

THE SHORTEST PATH TO POWER FROM LNG

iRPB: Optimizing CAPEX and expediting delivery

A unique patented architecture combines the T.EN integrated regas and power barge (iRPB) with an standard LNG carrier providing ultra competitive large-scale LNG storage.

- Optimized integrated floating regasification and power barge (iRPB) without LNG storage
- Pre-owner LNG carrier as floating LNG storage
- State-of-the-art continuous LNG flow-to-feed iRPB from floating storage
- LNG delivery through conventional ship-to-ship transfer

BENEFITS:

- Major CAPEX reduction versus traditional LNG-to-Power architectures
- Lower levelized cost of energy (LCoE)
- Plug-and-play LNG-to-Power with reduced construction schedule
- Multiple fabrication yards capable of iRPB construction, lowering construction costs and reducing schedule
- Optimized energy efficiency with LNG cold energy used for cooling

CAPEX BREAKDOWN

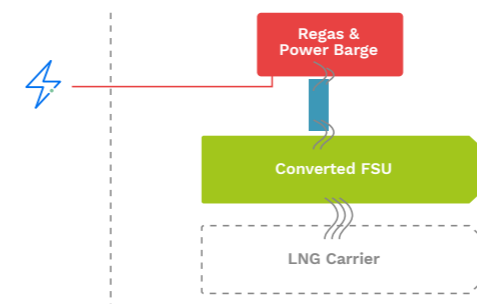
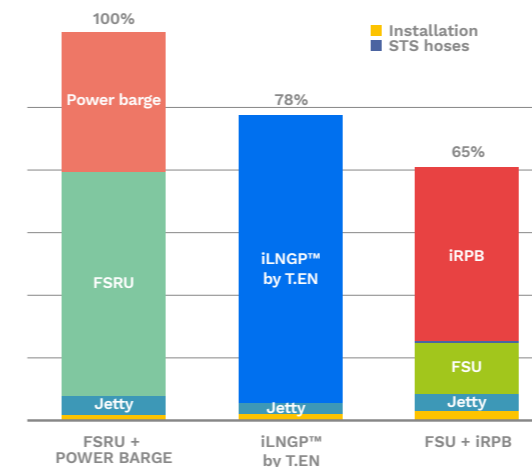

CCS-iLNGP: Flexible decarbonized LNG-to-Power station

With CO₂ capture integrated onboard, the CCS-iLNGP is the first fully decarbonized LNG-to-Power integrated unit, featuring ultra-low CO₂ emissions and on-demand power on a plug-and-play prefabricated unit.







CCS-iLNGP main features

- Post-combustion CO₂ capture based on mature amine capture technology
- 90% of remaining CO₂ in gas turbine exhaust captured, liquefied, stored and exported for sequestration
- Wet cooling towers prevent seawater temperature rise
- Highest possible efficiency with thermal integration between LNG regasification and CO₂ liquefaction
- CO₂ sequestration locally or remotely

Our suite of iLNGP by T.EN™ solutions

We offer small- to large-scale power units based on combined cycle gas turbines for high energy efficiency, dual fuel gas engines that provide full flexibility and options for minimum environmental impact and affordable investment.

GUARANTEED COST, SCHEDULE AND PERFORMANCE	
OUR BASE RANGE	ALTERNATES
 <p>"Affordable asset, simple operations"</p> <p>SMALL-SCALE</p> <ul style="list-style-type: none"> • 30--200MW typical power range • Dual fuel gas engines • Full flexibility to meet any power load factor 0-100% 	 <p>IRPB (FLOATING REGAS POWER BARGE)</p> <ul style="list-style-type: none"> • Separate floating LNG storage • Dual fuel gas engines or combined cycle gas turbines • Competitive CAPEX and optimized schedule
 <p>"Reliable and high efficiency solution"</p> <p>MID-SCALE</p> <ul style="list-style-type: none"> • 150-450 MW power range • Marinized combined cycle gas turbines (CCGT) • Exhaust gas heat recovery for high global efficiency • Scalable modular design 	 <p>CCS-iLNGP CARBON CAPTURE SOLUTION</p> <ul style="list-style-type: none"> • Local CO₂ sequestration or liquid CO₂ export • Recommended for mid-scale LNG-to-Power
 <p>"Customized to large-scale project"</p> <p>LARGE-SCALE</p> <ul style="list-style-type: none"> • 650-1300 MW typical power capacities • Customized design from project specific concept to FEED development • Marinized combined cycle gas turbines (CCGT) • Exhaust gas heat recovery for high global efficiency 	<p>OPTIONS</p> <p>OPTIONS FOR LNG & POWER HUB</p> <ul style="list-style-type: none"> • LNG and / or natural gas delivery to shore for truck distribution, local industries or domestic gas needs • Potable water production • LNG bunkering hub • Wet cooling tower for aerial cooling with no seawater temperature impact



Renaud Le Dévéhat
Head of Offshore Technology
Paris Expertise & Solutions
Tel: +33 (0)1 85 67 80 62
+33 (0)6 12 05 43 87
renaud.ledevehat@ten.com

Dominique Gadelle
VP Early Engagement Gas
Gas & Low Carbon Energies Business Line
Tel: +33 (0)6 74 56 31 81
dominique.gadelle@ten.com

www.ten.com